

SMART



60 / 80 / 100 *lt*

Electric fender with insulation increased and technology thermostat SMART

+ Why to choose it:

The smart thermostat that optimizes cycles heating, ensures the perfect combination of low energy consumption and hot water, always ready for use! The augmented thickness of the insulation (compared to classic models), makes this water heater the best answer to the new low consumption needs.

The SMART technology allows you to control the heating cycles even for longer periods of absence, with the possibility of ANTIFREEZE CYCLE and ANTI LEGIONEL CYCLE

TECHNICAL DATA

	SMART 60	SMART 80	SMART 100
Thermal Dispersiom 50° (KWh/24h)	0,79	0,97	1,18
Power (W)	1200	1200	1500
Voltage (v)	230	230	230
Heating time (Δt 50°)	175'	232'	245'
Max working temperature (C°)	65°	65°	65°
Max working pressure (bar)	8	8	8
Protection against humidity	IPX4	IPX4	IPX4
Insulation class	I	I	I
Profile	M	M	M
Energy Class	B	B	C

- +** **MEMORIZE** THE WATER WITHDRAWALS
- +** **CALCULATES THE DAILY REQUIREMENT** BASED ON YOUR CONSUMPTION
- +** **CONTROLS THE WATER HEATING PHASES** TO REDUCE HEAT LOSS AND OPTIMIZES THE AVAILABILITY OF HOT WATER
- +** **AUGMENTED INSULATION**

 COPPER HEATING ELEMENT	 THERMOSTAT	 LED CONTROL	 ROHS COMPONENT
 MAGNESIUM ANODE	 POLYURETHANE FOAM CFC FREE	 LOW NOISE WORKING	 ENVIRONMENT RESPECT
 ERP 2017	 SMOKE CONTROL		

DIMENSIONS

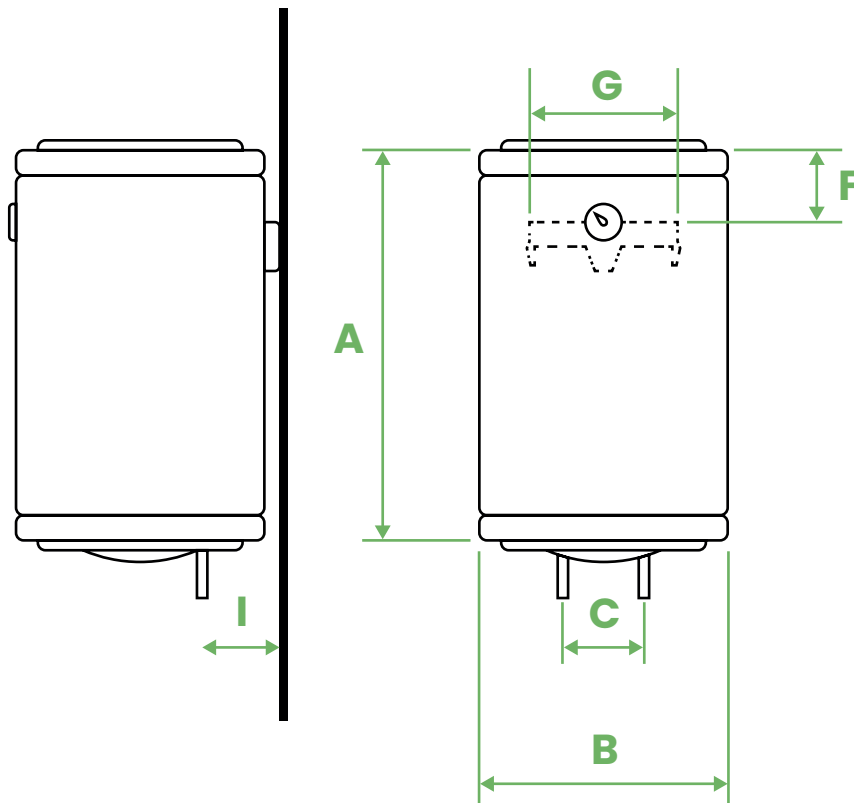

	A	B	C	F	G	I
SMART 60	600 mm	460 mm	100 mm	130 mm	350 mm	130 mm
SMART 80	760 mm	460 mm	100 mm	130 mm	350 mm	130 mm
SMART 100	960 mm	460 mm	100 mm	130 mm	350 mm	130 mm